

# AVAMIX

# IMMERSION BLENDEERS

COMMERCIAL BLENDERS

#928IB10 - 10" Immersion Blender

## MEDIUM DUTY

PERFECT FOR SAUCES & SOUPS!

- Variable Speed up to 16,000 RPM for Pureeing, Whipping, and Emulsifying
- Disassembles for Easy Cleaning
- 10" Stainless Steel Blending Shaft & Blade Assembly
- Shaft removes with ease
- 3/4 hp motor delivers superior power in its class to easily blend product
- Other attachments available for purchase



NEMA 5-15P



### OPTIONAL ACCESSORIES



#928PIB10WHSK  
Whisk



#928PISBWH  
Wallhanger



#928PIBBRT  
Blade Removal Tool

Shaft Sizes:

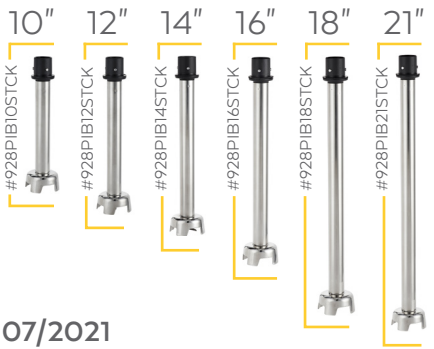

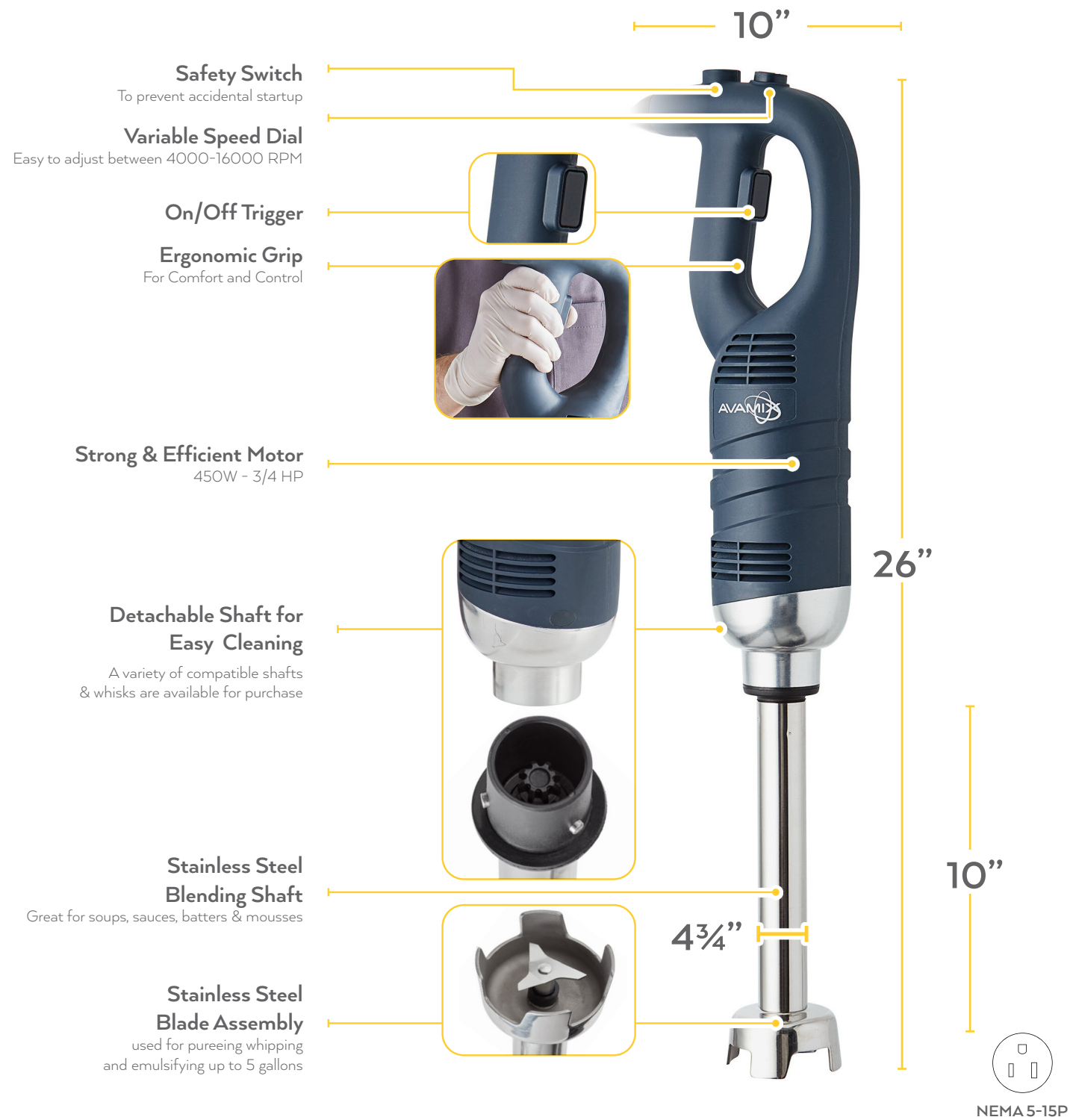

**WARRANTY - 1 YEAR REPLACEMENT**

**SPECIFICATIONS**

Dimensions (L" x W" x D")	Shaft Length	Amps	Hertz	Phase	Voltage	Wattage	Horsepower	RPM	Type	Speeds	Weight
26 in. x 4 3/4 in. x 10 in.	10 in.	3.75	60	1	120V	450W	3/4 HP	4,000 - 16,000	Medium Duty	Variable	9lb.